

**LEWMAR®**

# Electric/Hydraulic

TT Thruster 110 (1.5Kw) to 300TT (15Kw)

Gen 2 - 559231 Iss.1

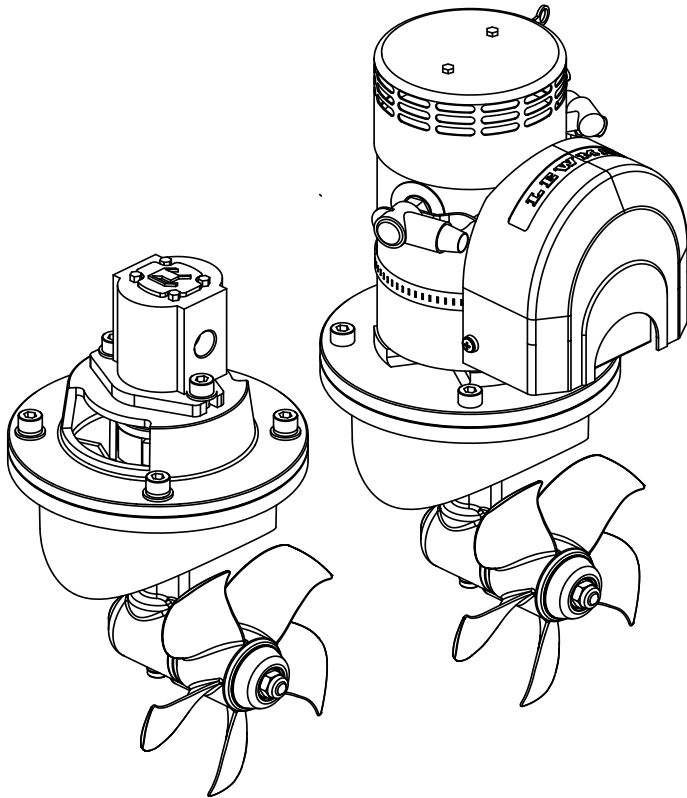

Owner's Installations, Operation & servicing manual

## 1- Introduction

Dear Customer,

Thank you for choosing Lewmar. Lewmar products are world renowned for their quality, technical innovation and proven performance. With a Lewmar product you will be provided with many years of outstanding service.

### Product support

Lewmar products are supported by a worldwide network of distributors and Authorised Service Representatives. If you encounter any difficulties with this product, please contact your national distributor, or your local Lewmar dealer. Details are available at: [www.lewmar.com](http://www.lewmar.com)

### CE Approvals

For CE approval certificates contact Lewmar.

### Important information about this manual

Throughout this manual, you will see safety and product damage warnings. You must follow these warnings carefully to avoid possible injury or damage.

## 2- Safety Notice

 WARNING!

### General

Please ensure that you thoroughly understand the operation and safety requirements of the thruster before commencing the installation. Only persons who are completely familiar with the controls and those who have been fully made aware of the correct use of the thruster should be allowed to use it. If there is any doubt of how to install or operate this unit please seek advice from a suitably qualified engineer.

- ▶ Please ensure that you thoroughly understand the operation and safety requirements of the thruster.
- ▶ Your thruster should not be operated close to swimmers, as a powerful suction of water is generated when in use.
- ▶ **The tunnel installation and any hull modifications should only be carried out by a specialist. This manual is based on a GRP tunnel installation.**
- ▶ We recommend that a qualified person install the thruster. Faulty installation will place the boat and crew in danger and make the warranty invalid.
- ▶ It is the unavoidable responsibility of the owner or master or other responsible party to assess the risk of any operation on the vessel.

### Thruster supply

- ▶ The thruster is securely packed for transit. However all parts should be inspected for signs of damage before installation. If any parts are found to be damaged please contact lewmar.

### Fitting

- ▶ This equipment must be installed and operated in accordance with the instructions contained in this manual. Failure to do so could result in poor product performance, personal injury and/or damage to your boat.
- ▶ Electric thrusters must be located in a dry environment. Should there be a need to install in a damp /wet location then the IP (Ignition Protected) version must be used.
- ▶ Electric bow thrusters use powerful electric motors, it is very important that there is sufficient battery capacity and large enough cables for safe operation. Using smaller than recommended battery and cables will cause loss of performance and may cause dangerous overheating.
- ▶ Electric motors spark and run hot. Do not place near flammable or sealed areas.
- ▶ Main battery must not be connected and power must not be switched on until all covers and terminal protectors are correctly fitted.
- ▶ It is very dangerous to run the thruster out of the water, even for a few seconds, the motor will over speed

by 300%, causing damage to the motor seals etc. and the propeller will cause serious damage to whatever comes into contact with it. This action will invalidate the warranty.

- ▶ Consult the boat manufacturer if you have any doubt about the strength or suitability of the mounting location.

**Electrical**

- ▶ Make sure you have switched off the power before you start installing this product.
- ▶ If in doubt about installing electrical equipment please seek advice from a suitably qualified electrical engineer.

To the best of our knowledge, the information in this manual was correct when it went to press. However, Lewmar cannot accept liability for any inaccuracies or omissions it may contain.

In addition, our policy of continuous product improvement may change specifications without notice. As a result, Lewmar cannot accept liability for any differences between the product and the manual.

⚠ This manual forms part of the product and **MUST BE RETAINED** along with, OR incorporated into, the Owner's Manual for the vessel to which the thruster is fitted.

**3- Installation**

**3.1 Choosing the location**

⚠ A competent, marine engineer must carry out any work on the hull of your boat.

⚠ The boat **MUST** be out of the water, levelled and secure in its cradle.

The actual position of the Thruster will depend on the internal & external construction of the Motor Boat or Sailing Yacht. For optimal performance the Thruster should be mounted within the following:

- ▶ As far forward as possible (Fig 3.1.1 / lever effect).
- ▶ 1 x Ø below the waterline to prevent air being sucked into the tunnel. (Fig. 3.1.2 / 0.75 x Ø minimum).
- ▶ Minimum suggested tunnel length 2 x Ø.

NOTE: Ensure there is sufficient space for the Thruster assembly complete with motor and controls in the boat.

**Ø = Tunnel Diameter**

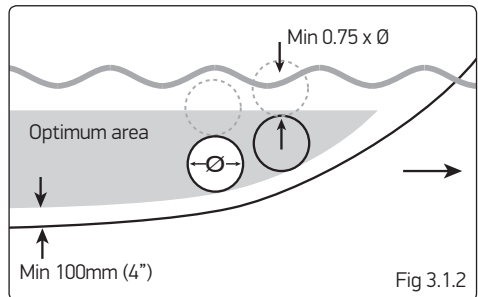
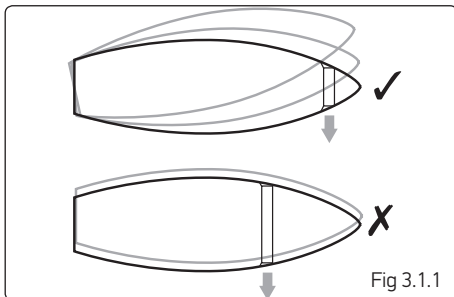

TT Thruster can be fitted new or as a replacement for an existing thruster. Tunnel dimensions listed on the following table.

NOTE: Check mounting holes on the saw template

THRUSTER MODEL (kW)	INSIDE DIAMETER		WALL THICKNESS	
	mm	inch	mm	inch
110	110	4 <sup>5</sup> / <sub>16</sub>	5.0	<sup>3</sup> / <sub>16</sub>
140	140	5 ½	4.0-5.0	<sup>5</sup> / <sub>32</sub> - <sup>3</sup> / <sub>16</sub>
185 (3.0 Ø 4.0)	185	7 <sup>9</sup> / <sub>32</sub>	4.0-6.0	<sup>5</sup> / <sub>32</sub> - ¼
185 (5.0 Ø 6.0)	185	7 <sup>9</sup> / <sub>32</sub>	6.0	¼
250	250	9 <sup>27</sup> / <sub>32</sub>	7.5	<sup>9</sup> / <sub>32</sub>
300	300	11 <sup>13</sup> / <sub>16</sub>	9.0	<sup>11</sup> / <sub>32</sub>

- ▶ The recommended tunnel is designed to fit a Lewmar saddle, take the weight of the Thruster and the torque of the motor.
- ▶ Fig 3.1.3 - To reduce any potential loss of performance or damage to the propeller the entrance of the tunnel can be altered to improve thrust as well as reduce noise.

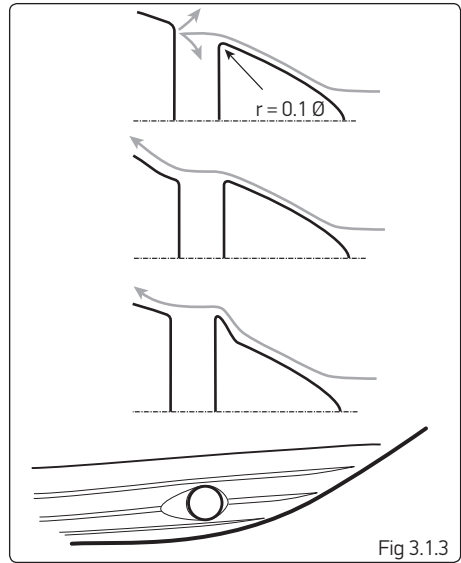

Fig 3.1.3

## 3.2 Preparing the hole for the tube

⚠ For general guidance for GRP boats only. Problems caused by faulty installation of the tunnel are the installers full responsibility.

⚠ A competent, marine engineer must carry out any work on the hull of your boat.

When you are satisfied the best location for the Thruster unit has been found within the parameters available proceed as follows.

- ▶ Fig 3.2.1 - Make a jig to precisely align the drill holes either side of the hull.

NOTE: Double check everything before drilling.

- ▶ Drill a pilot hole in both sides of the hull.

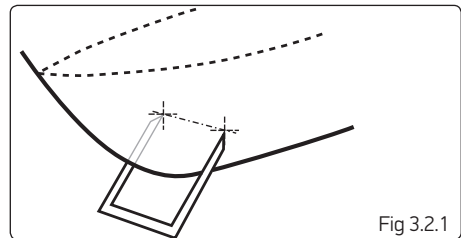

Fig 3.2.1

- ▶ Form a wire guide to diameter of the tunnel hole, mark, check and cut.
- ▶ Insert tube in the hole, mark and remove excess.

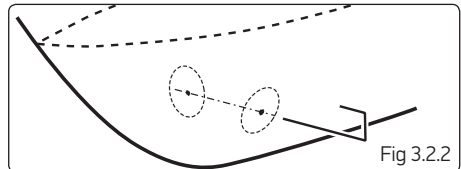

Fig 3.2.2

- ▶ Grind off gel coat etc. Insert tunnel and fix allowing enough room inside for saddle location on the tunnel.
- ▶ Gel coat finished installation and anti foul.

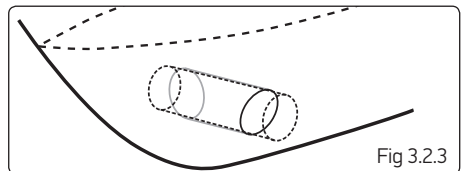

Fig 3.2.3

### 3.3 Preparing for fitting the thruster

- ▶ The Thruster can be installed at any angle within 90° from vertical.

⚠ Electric motors must be supported if installed more than 30° from vertical (Fig 3.3.1).

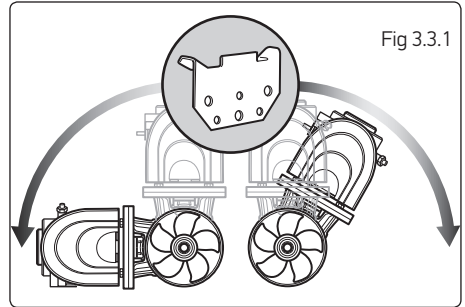

Fig 3.3.1

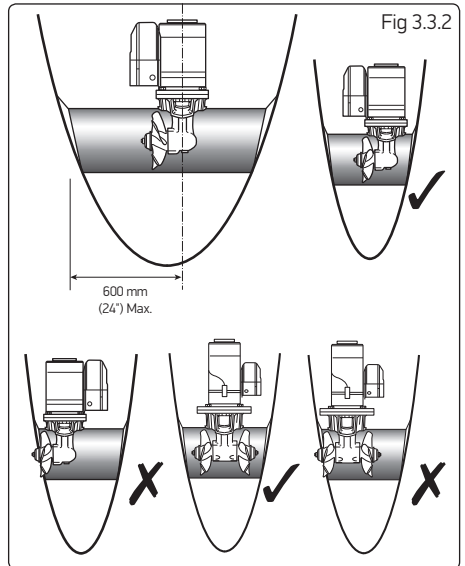

Fig 3.3.2

- ▶ Choose position of thruster, ensuring internal room for motor and controls and that the propeller is easily reached from outside.

NOTE: Fig 3.3.2. - Normal install is to Port (single propeller unit)

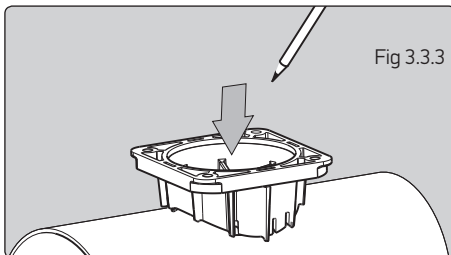

Fig 3.3.3

- ▶ Place the thruster saddle in the desired position, ensure the fit is firm and free from movement then mark centre.

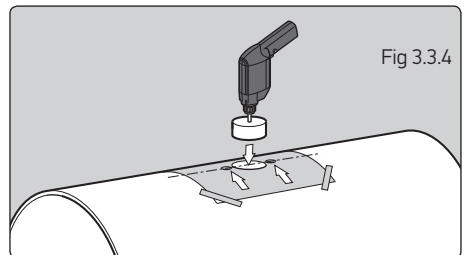
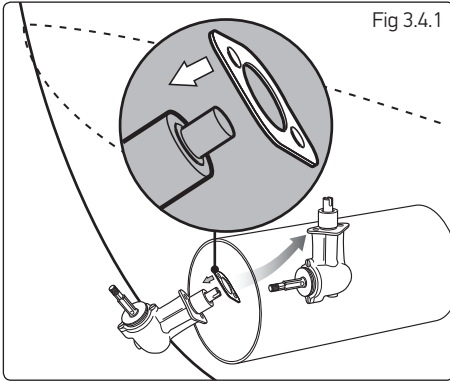

Fig 3.3.4

- ▶ **Position template on centre line, verify correct and carefully cut thruster hub hole using an appropriate hole saw for GRP and applying light cutting pressure only taking care not to splinter the tube. Remove any burrs with care, seal with resin mix and fair as required.**
- ▶ **Note: Poor alignment may affect hub positioning.**

### 3.4 Installing hub unit and saddle - 140TT & 185TT models



**Note: illustrations based on 140TT saddle**

- ▶ To suit the wiring configuration supplied fit the thruster propeller on the port side.
- ▶ Place gasket on hub and locate through centre hole. Sealant can be applied to gasket and flange to aid sealing.

**NOTE:** To achieve the correct position of the propeller in the tunnel the gasket must be in place.

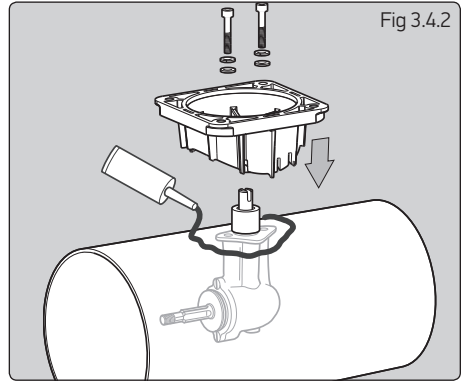

**NOTE: Poor exterior tunnel surface could cause leakage and noise. Apply sealant to this area as required (Fig. 3.4.2).**

- ▶ Apply zinc chromate paste or marine grease to location bore and assemble saddle onto hub (SikaFlex® or similar maybe used to seal saddle in place). Apply Blue Loctite® 243 to bolts and hand tighten along with supplied washers (Fig. 3.4.2).

**NOTE:** Tighten to full torque within 10 minutes.

### 3.5 Gearbox position - 185TT models

On installation check the position of the gearbox (leg) stem in the saddle.

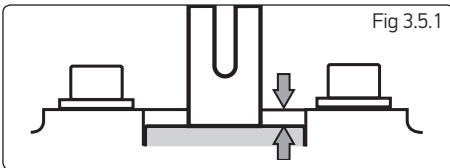

- ▶ If it is below 2 mm ( $1/16$ " ), material must be removed from the tunnel (Fig 3.5.1).

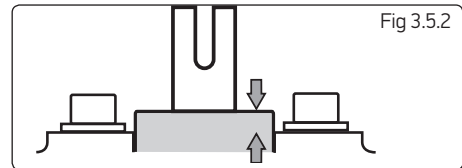

- ▶ If it is above 3.5 mm ( $1/8$ " ), the tunnel should be packed under the saddle (Fig 3.5.2).

### 3.6 Propeller assembly - all models

- ▶ Check the hub gasket is in place.
- ▶ Fig 3.6.1 - Assemble anode kit and propeller in this order: large washer, propeller, anode, small washer and nyloc nut onto propeller shaft.

⚠ Check the propeller has been assembled in the correct order.

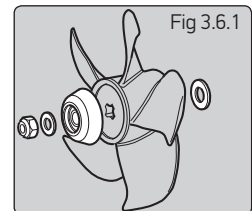

**Note: Tighten each bolt alternately a number of times to full torque.**

- ▶ Fig 3.6.2 - Tighten hub/saddle bolts to 9 Nm (6.6 lb.ft) for 140 or 21 Nm (15.5 lbs.ft) for 185.

⊘ DO NOT allow propeller to touch tunnel.

⊘ DO NOT anti foul zinc anode

- ▶ Fig 3.6.3 - Check that propeller is centred and free turning (within 10 minutes of applying Blue Loctite® 243).

- ▶ Anti foul bronze hub and propeller if desired.

- ▶ Tighten propeller nut to 10 Nm (7.4 lbs.ft) for 140 or 15 Nm (11 lbs.ft) for 185, a length of wood placed between propeller blade and tunnel will stop movement.

⊘ DO NOT overtighten propeller nuts.

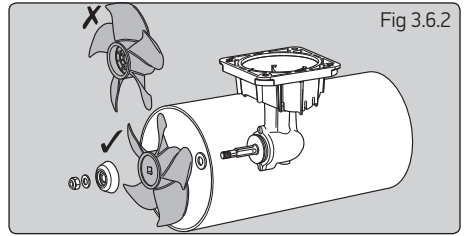

Fig 3.6.2

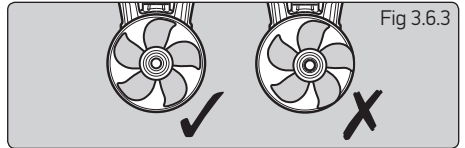

Fig 3.6.3

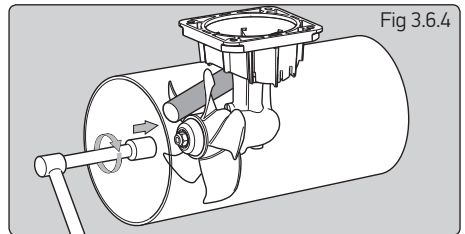

Fig 3.6.4

### 3.7 Installing hub unit and saddle models 250TT & 300TT

- ▶ Place gasket on hub and locate through centre hole. Sealant can be applied to gasket and flange to aid sealing.

**NOTE: To achieve the correct position of the propeller in the tunnel the gasket must be in place.**

**NOTE: Poor exterior tunnel surface could cause leakage and noise. Apply sealant to this area as required (Fig 3.7.2).**

- ▶ Apply zinc chromate paste or marine grease to location bore and assemble saddle onto hub (SikaFlex® or similar maybe used to seal saddle in place). Apply Blue Loctite® 243 to bolts and hand tighten along with supplied washers (Fig 3.7.2).

**NOTE: Tighten to full torque within 10 min**

**NOTE: Tighten each bolt alternately a number of times to full torque.**

- ▶ Tighten hub/saddle bolts to 33 Nm (24 lbs.ft) for 250 or 82 Nm (60.5 lbs.ft) for 300. Check that propeller is centred and free turning (within 10 minutes of applying Blue Loctite® 243).

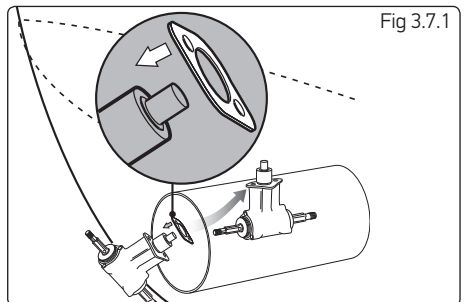

Fig 3.7.1

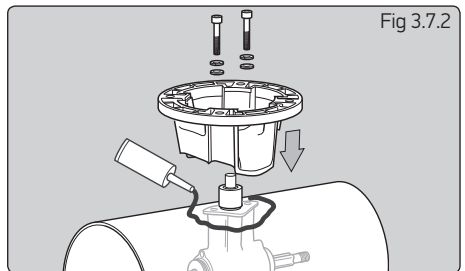

Fig 3.7.2

- ▶ Assemble anode kit and propeller in this order:- large washer, propeller, anode, small washer and nyloc nut onto propeller shaft. To suit the wiring configuration supplied fit the thruster LH propeller on the port side.

⚠ Check the propeller has been assembled correctly (Fig 3.6.1).

⊘ DO NOT allow propeller to touch tunnel.

⊘ DO NOT anti foul zinc anode

- ▶ Anti foul bronze hub and propeller if desired.

- ▶ Tighten propeller nut to 35 Nm (26 lbs.ft), a length of wood placed between propeller blade and tunnel will stop movement.

⊘ DO NOT overtighten propeller nuts.

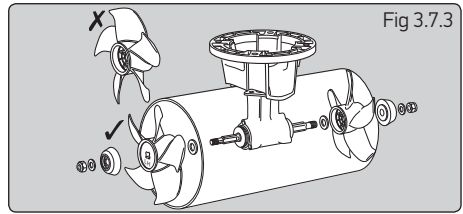

Fig 3.7.3

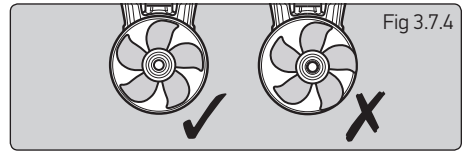

Fig 3.7.4

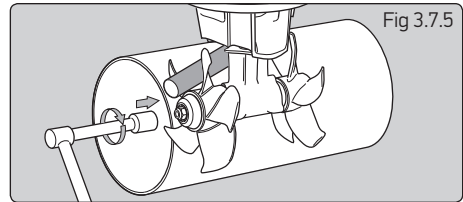

Fig 3.7.5

### 3.8 Electric motor unit support

If the electric motor is installed more than 30° from the vertical it MUST be supported and secured to the support with a strap (See Accessories) around the main motor unit.

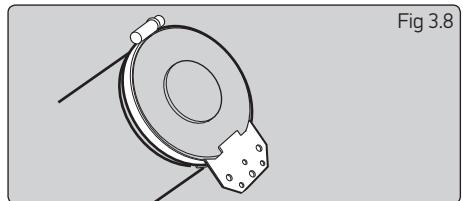

Fig 3.8

### 3.9 Installing electric motor unit - 110TT & 185TT models

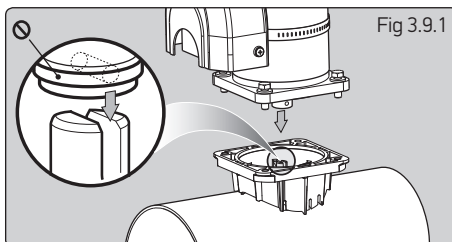

Fig 3.9.1

**Note: illustrations based on 140TT saddle**

- ▶ Align motor drive pin in line with slot in shaft. Apply grease to hub shaft.

⊘ DO NOT REMOVE the drive pin plastic retainer tie on the motor drive shaft.

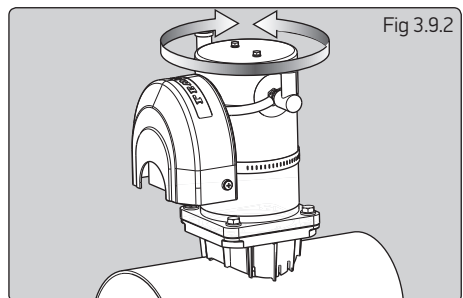

Fig 3.9.2

- ▶ Slide motor into position and align holes for most suitable installation.
- ▶ Bolt motor assembly to saddle and tighten bolts to 20 Nm (15 lbs.ft) for 140 or 35 Nm (25.8 lbs.ft) for 185. Apply Blue Loctite® 243 to all bolts.



### 3.10 Installing electric motor unit model 250TT & 300TT

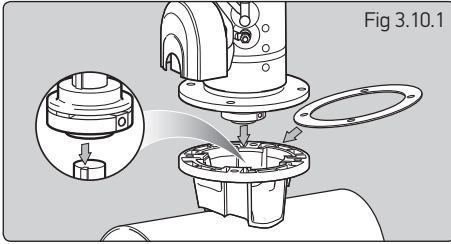

Fig 3.10.1

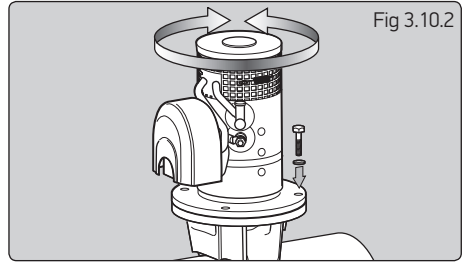

Fig 3.10.2

⊘ Coupling is factory fitted. DO NOT remove.

- ▶ Place insulator in between saddle and motor flange. Line up key to coupling keyway.

- ▶ Remove drive shaft key retaining tie, grease shaft, slide motor into position and align holes for most suitable installation and bolt motor assembly to saddle applying Blue Loctite® 243 to bolts.

### 3.11 Installing hydraulic motor unit model 185TTH to 300TTH

⊘ Coupling is factory fitted. DO NOT remove.

- ▶ Place insulator in between saddle and motor flange. Line up key to coupling keyway.

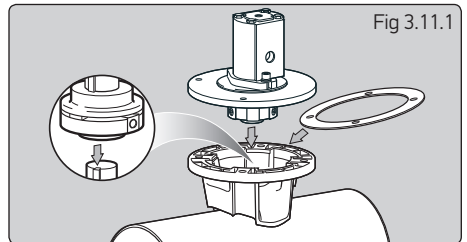

Fig 3.11.1

- ▶ Remove drive shaft key retaining tie, grease shaft, slide motor into position and align holes to saddle and tighten.

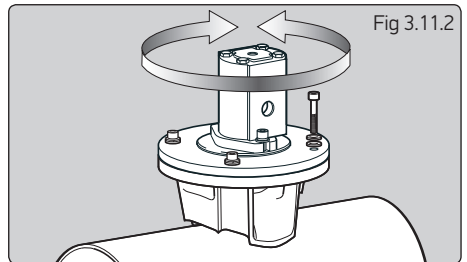

Fig 3.11.2

- ▶ Motor ports require male/female connectors with correct size hydraulic sealing washers.  
185TTH Main ports = 3/8" BSPP.  
Main ports = 3/4" BSPP.  
Drain ports = 1/4" BSPP.

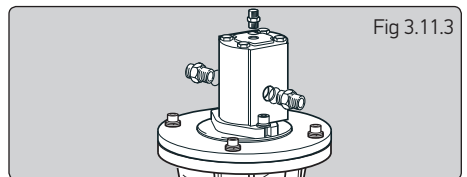

Fig 3.11.3

**NOTE: It is advisable to fit insulated pipe sections to prevent thruster corrosion.**

MODEL	PART N°	MAX OUTPUT	MOTOR DISP.	DELTA	FLOW	MAX THRUST
185TTH	591820	7 kW	6 cc/rev	210 bar	26 l/min	100 Kgf
250TTH	592520	15 kW	26 cc/rev	122 bar	81.5 l/min	200 Kgf
250TTH	592521	15 kW	17 cc/rev	190 bar	52.3 l/min	200 Kgf
300TTH	593020	22.5 kW	30 cc/rev	182 bar	82.1 l/min	300 kgf
300TTH	593021	22.5 kW	26 cc/rev	210 bar	71.7 l/min	300 Kgf

## 3.12 Final checks - All models

### Check list hydraulic

- ▶ Check drain line fitted.
- ▶ All fittings are tight with seals in place.
- ▶ Hydraulic system has been checked and adjusted to correct pressures and flows.

### Operation of Hydraulic unit

- ▶ Refer to system suppliers instructions.

### Check list mechanical

- ▶ Check all bolts and nuts are tight.
- ▶ Check the propeller/s are correctly installed and the nuts tightened.
- ▶ Check the motor control box cover is in place.
- ▶ Check the propeller/s can be turned - before working on unit check battery switch is off or remove the fuse.

**NOTE: Saddle and motor are firmly seated on the tube.**

## 4- Electrical wiring installation

### 4.1 Typical electrical layout model110TT 1.5 kW and 185TT

If the thruster operates in an opposite direction to the control panel, swap the contactor wire connections on the contactor coils.

**NOTE: Automatic switch (if fitted). Main power is switched on when panel is switched on.**

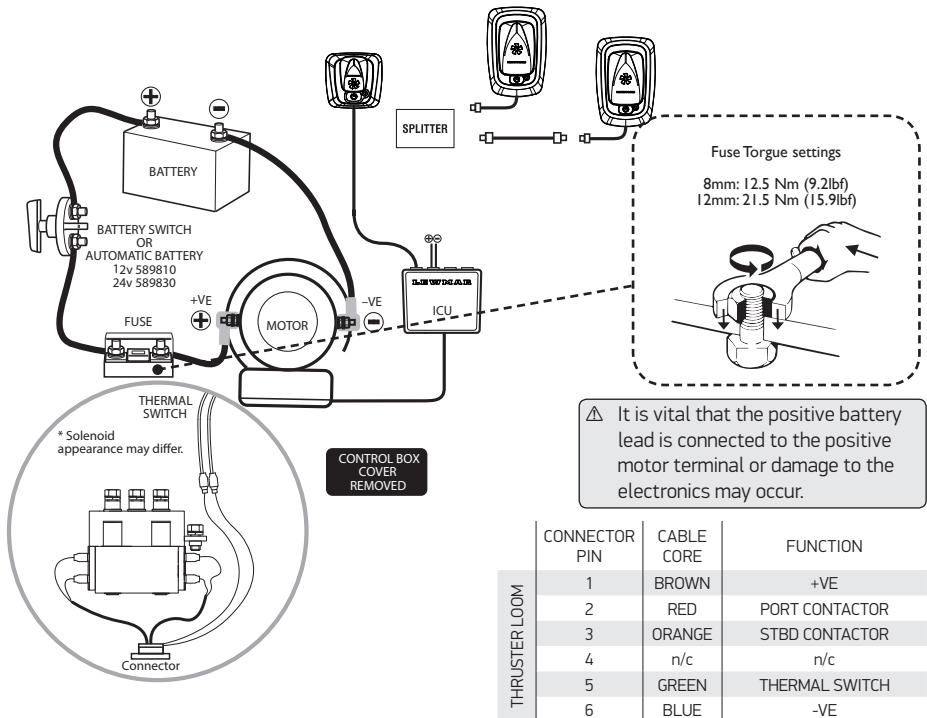

**4.2 Typical electrical layout model 250TT & 300TT**

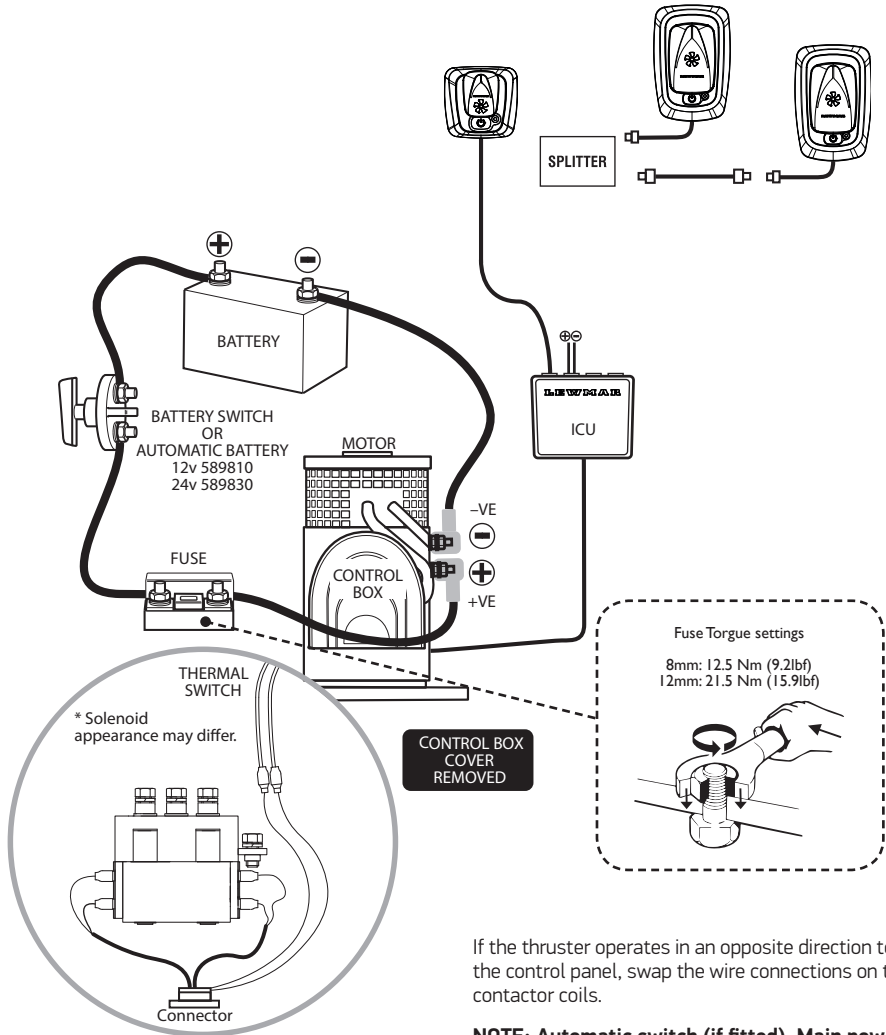

If the thruster operates in an opposite direction to the control panel, swap the wire connections on the contactor coils.

**NOTE: Automatic switch (if fitted). Main power is switched on when thrusting.**

⚠ It is vital that the positive battery lead is connected to the positive motor terminal or damage to the electronics may occur.

**NOTE: For dual controls see stern thruster manual included in stern kit or on [www.lewmar.com](http://www.lewmar.com)**

	CONNECTOR PIN	CABLE CORE	FUNCTION
THRUSTER LOOM	1	BROWN	+VE
	2	RED	PORT CONTACTOR
	3	ORANGE	STBD CONTACTOR
	4	n/c	n/c
	5	GREEN	THERMAL SWITCH
	6	BLUE	-VE

### 4.3 Electric motor terminal connections

- ▶ Terminals must be correctly clamped to motor studs. Use a pair of spanners - the one nearest motor to stop rotation of the stud.
- ▶ Spanner sizes are 13 mm for 110TT & 140TT and 17 mm for 185TT - 300TT. Tighten the bolts to 20 Nm (15 lbs.ft).

⊘ DO NOT overtighten electric motor terminal nuts.

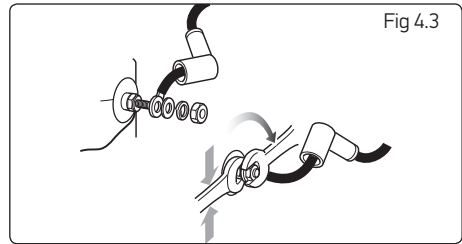

### 4.4 Battery cable connections

⚠ Incorrect installation of battery cables or damage to connection studs may result in a short to the thruster body. Use the examples above to check for a correct installation on both +V and -V battery connections.

- ▶ Correct installation. Supplied cable boots are used and no bare wires exposed (Fig 4.4.1).
- ▶ Live wire exposed! (Fig. 4.4.2). Correct the cable installation to match (Fig 4.4.1).
- ▶ Terminal or motor is damaged. Contact Lewmar Limited (Fig 4.4.3).
- ▶ Crimp inverted and is touching motor! (Fig 4.4.4). Correct the cable installation to match as (Fig 4.4.1).

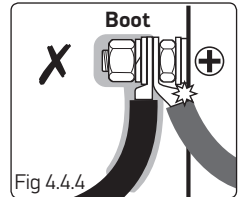
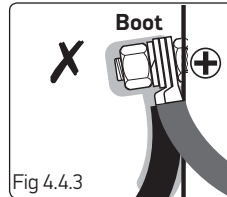
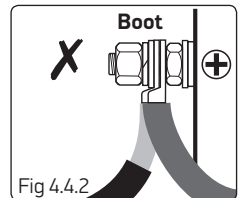
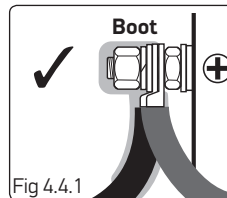

### 4.5 Correct cable sizes

**NOTE: Cable length is total from battery to thruster and back.**

- ▶ Example: Measure the total cable run from the battery to thruster and back in metres. Grey area on the table shows a total of 28 m (92 ft) of cable with a model 250 8.0 kW thruster would need 95 mm CSA (000 AWG) cable.
- ▶ Battery crank capacity should be at least equal to the thruster current.
- ▶ Main power cables should be run from the batteries and must have an in line fuse fitted.

⊘ The installation **MUST** have a battery switch that is switched off whilst the thruster is not in use or the boat is unoccupied.

- ▶ The cables should be terminated with a ring terminal corresponding to the motor studs, 8 mm (5/16") for 140TT and 10 mm (3/8") for 185TT, 250TT and 300TT. It is important that this termination is secure so that the high current is transferred to the motor efficiently. The minimum voltage at motor when running should be 10V for 12V and 21V for 24 V units.
- ▶ Ensure the insulating boots, supplied with the unit, are correctly fitted.

**NOTE: If very large cables are used discard supplied boots and fit appropriate sized ones.**

TT MODEL	VOLTAGE	STATED CURRENT DRAW	MIN CALBLE SIZE	MAX CABLE LENGTH AT MIN CABLE SIZE
110 1.5KW	12	215	50	12
140 2.0KW	12	270	70	14
140 2.2 KW	12	280	70	12
185 3 KW	12	330	95	15
185 3 KW	24	160	35	12
185 4 KW	12	470	150	16
185 4 KW	24	235	70	16
185 5 KW	12	480	185	21
185 5 KW	24	240	70	15
185 6 KW	12	700	300	22
185 6 KW	24	370	120	18
250 8 KW	224	500	185	20
250 9.6 KW	48	330	95	15
300 10.8 KW	24	650	300	25
300 15.0 KW	48	420	150	18

### 4.6 Electrolytic test

⚠ To prevent electrolytic corrosion or faults, the thruster motor body and assembly **MUST** remain isolated from any power supply or grounds. The installer can check for this using a multimeter in the following ways.

#### Test 1. Fig 4.7.1

With the negative not connected and the positive cable connected but with battery switch off or fuse removed. Use a continuity tester to check for a connection between the -VE stud and motor body and also between +VE stud and motor body. In both cases the meter should give no indication of an electrical connection.

If a connection is measured between the +VE stud and the motor body, check installation for cables or wires touching the assembly or for damage to assembly.

If a connection is measured between the -VE stud and the motor body, remove any bonding straps attached to the assembly and check as before.

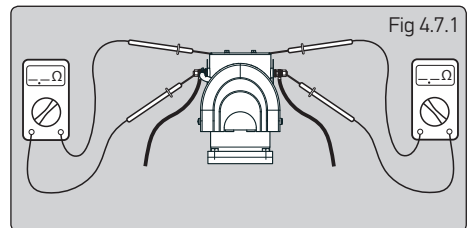

#### Test 2. Fig 4.7.2

With the battery applied: Use a voltmeter to test the voltage between the -VE motor stud and the thruster motor body. If the supply voltage (12V / 24V) is measured, disconnect power immediately and inspect the assembly for faulty installation or damage.

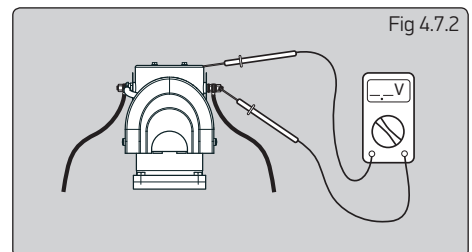

## 4.7 Installing control panel - all models

A 63.5 mm (2½") hole saw is required. Ensure there is sufficient depth for the control panel and access for the switch leads and plug (see saw template).

The panel has an pre-installed seal and is secured with the 4x screws included in the packaging  
The small plug connects at the panel. If two or more panels are installed use the optional Y connectors (Sec 6.6).

The auxiliary wire is used to connect an automatic battery switch. Please refer to the units instructions.  
If automatic battery switch not fitted, disregard auxiliary wire.

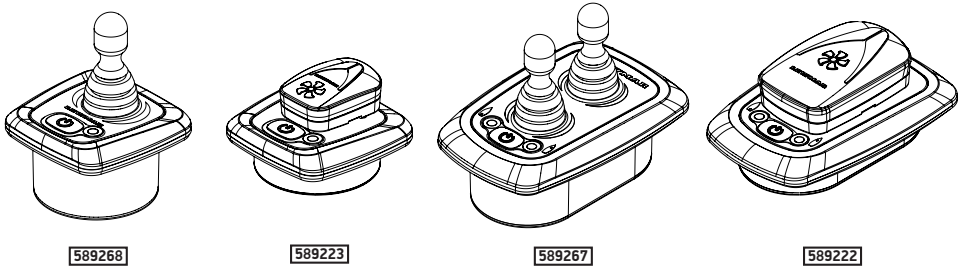
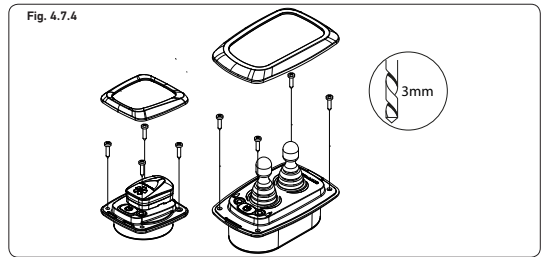
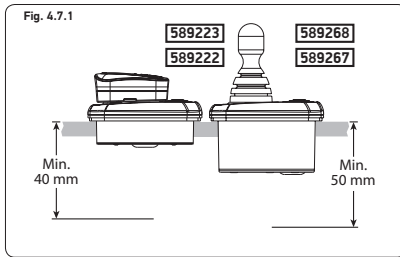

## 4.8 Final checks

⊘ Check the power is OFF

⚠ The thruster must not be operated unless it is in water.

### Check list electrical

- ▶ Check motor connections are tight with rubber boots in place.
- ▶ The correct fuse is in place.
- ▶ Check all switch wires are connected to correct motor terminal.
- ▶ Now the cables can be connected to the battery.
- ▶ Perform electrical check , Section 2.8.

### Operation of electrical unit

- ▶ Ensure batteries are fully charged before switching on the main power.
- ▶ When first operating the thruster, make sure you are not close to other vessels.

## 4.9 110TT 1.5kW to 300TT 15kW Operation and safety features

### Turning system On/Off

- ▶ To turn the system on press and hold the ON button for 1 second. If the system is active the panel LED will turn green.
- ▶ To turn the system OFF press the ON button once. The system will turn off immediately. The LED will switch off.
- ▶ If the system is in fault mode (Solid RED LED) Pressing the ON button will turn the system off.

### Safety Features

- ▶ If the thruster is operated constantly in one direction for more than 3 minutes, the system will enter fault mode. When in fault mode, the control panel LED will turn RED.
- ▶ If the system is receiving a PORT/STBD signal when turning the system on, the system will enter fault mode. When in fault mode, the control panel LED will turn RED. This prevents the thruster from unintentionally activating during start-up due to a wiring fault, or a second joystick accidentally being operated.
- ▶ If PORT and STBD signals are received simultaneously then the system will stop thrusting.
- ▶ The system will automatically power down after 15 minutes of inactivity for TT, & 5 minutes for RT thrusters.
- ▶ When changing thrust instantly from PORT to STBD / vice-versa there will be a short delay to allow the propeller to come to rest before acceleration in the opposite direction.
- ▶ The thruster motor is fitted with a thermal switch to prevent thruster activation if the motor overheats. If the motor temperature is too high the system will stop operating and the panel LED will FLASH RED. Once the motor returns to a safe temperature the LED will turn GREEN and thruster operation can recommence.
- ▶ The system will detect if the battery voltage is low and indicate this by turning the control panel LED AMBER. This is for indication only and will not affect thruster performance.

### LED Colour Diagnostics

COLOUR	STATUS
Green	System ON
Amber	Low Voltage
Red (Flashing)	Motor High Temperature
Red	Fault

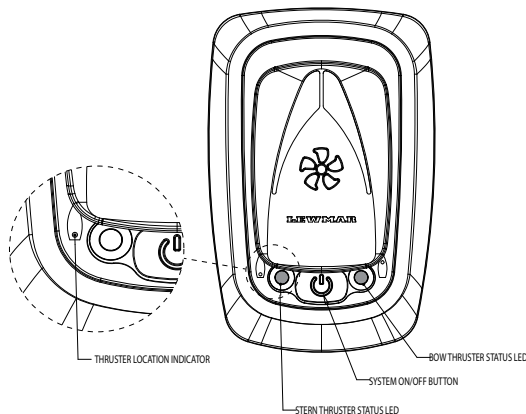

## 5- Servicing your thruster

### 5.1 Service schedule

**Thrusters are more likely to attract 'debris', so it is necessary to regularly check the tunnel.**

#### New install:

The anode should be checked after approximately 3 - 4 months to gauge an appropriate replacement schedule.

#### At the annual boat service:

- ▶ Remove any debris from tunnel, propeller and hub.
- ▶ Replace the anode.
- ▶ If the propeller is damaged or heavily contaminated, replace it, best to be safe.
- ▶ Apply grease to exposed thruster seal and shaft.
- ▶ If hub is removed the tunnel gasket must be replaced.
- ▶ Inspect motor, ensure all leads are still tight.

- ▶ Check all bolts and nuts are to correct torque.
- ▶ Check the motor assembly is dry and that the compartment is water tight.
- ▶ Check and clean out thruster compartment.

#### Electric:

- ▶ Inspect electric motor, ensure all leads are still tight.
- ▶ Brush out carbon dust from top of electric motor especially on aluminium boats. Recommend qualified electrician.

#### Hydraulic:

Refer to hydraulic system supplier for service requirements.

### 5.2 Changing drive pin 110TT, 140TT, 185TT

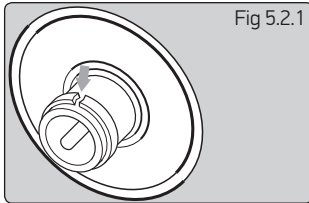

Fig 5.2.1  
Cut cable tie on shaft (if fitted)

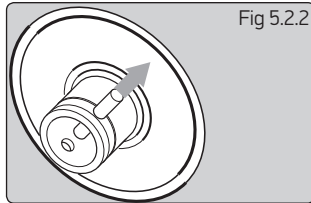

Fig 5.2.2  
Punch out pin parts

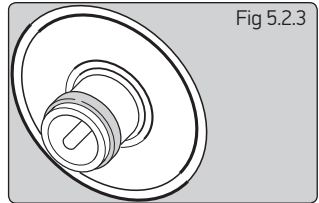

Fig 5.2.3  
Tap in new pin and secure with new plastic cable tie

#### Additional controller

Pressing opposite button on a second control panel when thruster is operating will cancel operation of thruster  
Operating same direction button when still in operation on other control panel will have no effect.



## 6- Weight & Specifications

### 6.1 Electric

PART NO	DESCRIPTION	TUNNEL SIZE (MM)	POWER		MOTOR VOLTAGE	IP	GEARBOX MATERIAL	PROPELLER	THRUST		WEIGHT		FUSE		FUSE HOLDER	
			KW	HP					KGF	LBS	KG	LBS	RATING	PART NUMBER		
590000	TT 110 12v	110	1.5	2.0	12v		Composite	Single 5 Blade	28	62	10	22	200A	589012	T1 - 589006	T2 - 589013
590001	TT 110 12v IP	110	1.5	2.0	12v	✓	Composite	Single 5 Blade	28	62	11	25	200A	589012	✓	✓
590002	TT 140 2.0Kw 12v	140	2.0	2.7	12v		Composite	Single 5 Blade	37	82	13	29	200A	589012	✓	✓
590003	TT 140 2.2Kw 12v	140	2.2	3.0	12v		Composite	Single 5 Blade	42	93	13	29	200A	589012	✓	✓
590004	TT 140 2.0Kw 12v IP	140	2.0	2.8	12v	✓	Composite	Single 5 Blade	37	82	14	31	200A	589012	✓	✓
590005	TT 140 2.2Kw 12v IP	140	2.2	3.0	12v	✓	Composite	Single 5 Blade	42	93	14	31	200A	589012	✓	✓
590006	TT 185 3.0Kw 12v	185	3.0	4.0	12v		st/st	Single 5 Blade	58	128	20	43	250	589008	✓	✓
590007	TT 185 3.0Kw 24v	185	3.0	4.0	24v		st/st	Single 5 Blade	58	128	20	43	130A	589007	✓	✓
590008	TT 185 4.0Kw 12v	185	4.0	5.4	12v		st/st	Single 5 Blade	65	143	20	43	400A	589010	✓	✓
590009	TT 185 4.0Kw 24v	185	4.0	5.4	24v		st/st	Single 5 Blade	65	143	20	43	130A	589007	✓	✓
590010	TT 185 5.0Kw 12v	185	5.0	6.7	12v		st/st	Single 5 Blade	82	181	27	59	400A	589010	✓	✓
590011	TT 185 5.0Kw 24v	185	5.0	6.7	24v		st/st	Single 5 Blade	82	181	27	59	130A	589007	✓	✓
590012	TT 185 6.0Kw 12v	185	6.0	8.0	12v		st/st	Single 5 Blade	97	214	27	59	500A	589011	✓	✓
590013	TT 185 6.0Kw 24v	185	6.0	8.0	24v		st/st	Single 5 Blade	97	214	27	59	325A	589009	✓	✓
590014	TT 185 3.0Kw 12v IP	185	3.0	4.0	12v	✓	st/st	Single 5 Blade	58	128	21	47	250A	589008	✓	✓
590015	TT 185 3.0Kw 24v IP	185	3.0	4.0	24v	✓	st/st	Single 5 Blade	58	128	21	47	130A	589007	✓	✓
590016	TT 185 4.0Kw 12v IP	185	4.0	5.4	12v	✓	st/st	Single 5 Blade	65	143	21	47	400A	589010	✓	✓
590017	TT 185 4.0Kw 24v IP	185	4.0	5.4	24v	✓	st/st	Single 5 Blade	65	143	21	47	130A	589007	✓	✓
590018	TT 185 5.0Kw 12v IP	185	5.0	6.7	12v	✓	st/st	Single 5 Blade	82	181	28	62	400A	589010	✓	✓
590019	TT 185 5.0Kw 24v IP	185	5.0	6.7	24v	✓	st/st	Single 5 Blade	82	181	28	62	130A	589007	✓	✓
590020	TT 185 6.0Kw 12v IP	185	6.0	8.0	12v	✓	st/st	Single 5 Blade	97	214	28	62	500A	589011	✓	✓
590021	TT 185 6.0Kw 24v IP	185	6.0	8.0	24v	✓	st/st	Single 5 Blade	97	214	28	62	325A	589009	✓	✓
590022	TT 250 8.0Kw 24v AL	250	8.0	10.8	24v		Aluminium	Twin CR 5 Blade	140	308	46	101	400A	589010	✓	✓
590024	TT 250 8.0 24v	250	8.0	10.8	24v		Bronze	Twin CR 5 Blade	140	308	46	101	400A	589010	✓	✓
590025	TT 250 9.6 48v	250	9.6	13.0	48v		Bronze	Twin CR 5 Blade	170	374	50	110	250A	589008	✓	✓
590033	TT 300 10.8 24v AL	300	10.8	14.5	24v		Aluminium	Twin CR 5 Blade	250	550	65	143	400A	589010	✓	✓
590034	TT 300 10.8 24v	300	10.8	14.5	24v		Bronze	Twin CR 5 Blade	250	550	65	143	500A	589011	✓	✓
590035	TT 300 15.0 48v	300	15.0	20.0	48v		Bronze	Twin CR 5 Blade	280	616	68	150	400A	589010	✓	✓

PART NO	DESCRIPTION	TUNNEL SIZE (MM)	POWER		PROPELLER	THRUST		WEIGHT	
			KW	HP		KGF	LBS	KG	LBS
590054	TT 185 Hyd Gen 2	185	7.0	10.0	Single 5 Blade	100	220	8	17.5
590055	TT 250 Hyd Gen 2	250	15.0	20.0	Twin CR 5 Blade	200	240	13	28.5
590056	TT 300 Hyd Gen 2	300	22.5	30.0	Twin CR 5 Blade	300	660	17	37.5

## 7- Parts list

## 7.1 Model 110TT 1.5kW 12V

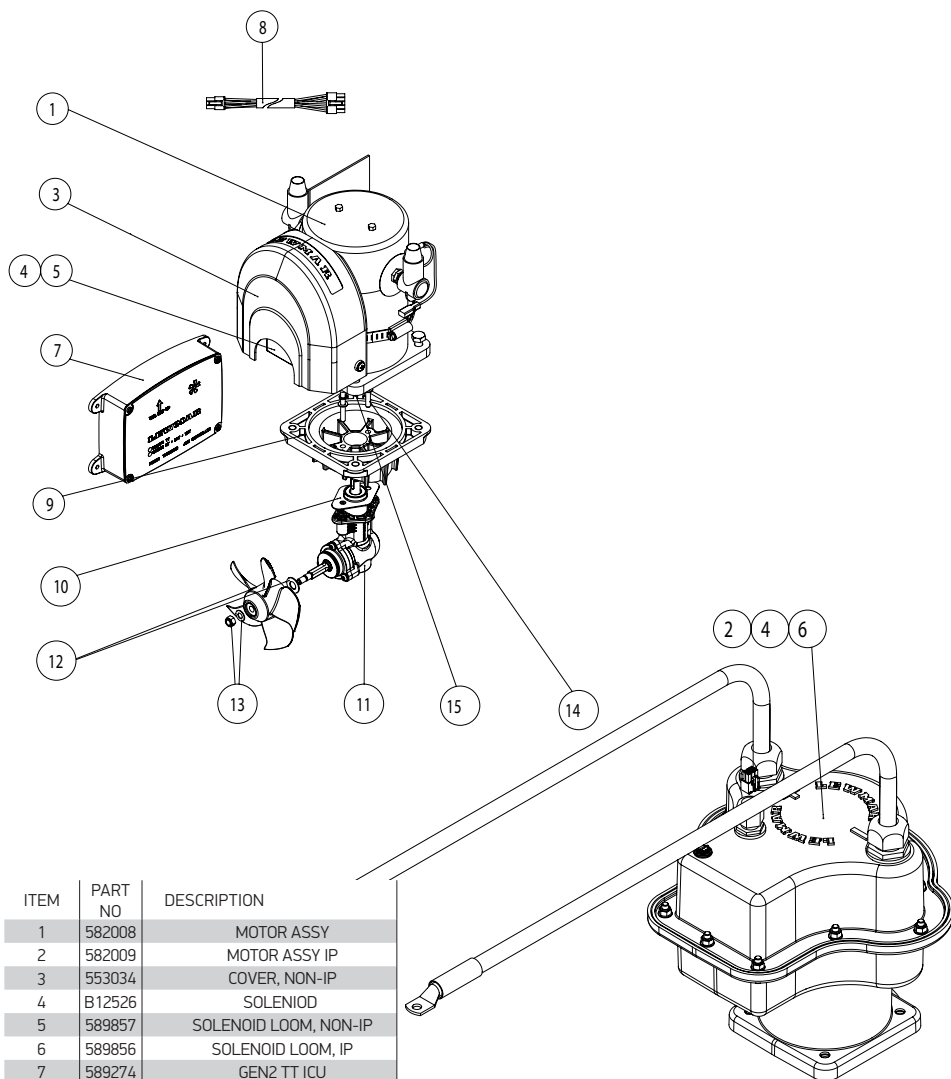

ITEM	PART NO	DESCRIPTION
1	582008	MOTOR ASSY
2	582009	MOTOR ASSY IP
3	553034	COVER, NON-IP
4	B12526	SOLENIOD
5	589857	SOLENIOD LOOM, NON-IP
6	589856	SOLENIOD LOOM, IP
7	589274	GEN2 TT ICU
8	589806	2m TT MOTOR LOOM
9	552004	MOUNTING SADDLE
10	552005	TUNNEL GASKET
11	582001	HUB ASSY
12	589451	PROPELLER AND WASHER
13	589453	PROPELLER FIXING KIT
14	589452	INSTALLATION FIXING KIT
15	559107	DRIVE PIN

**7.2 Model 140TT 2.2kW 12V**

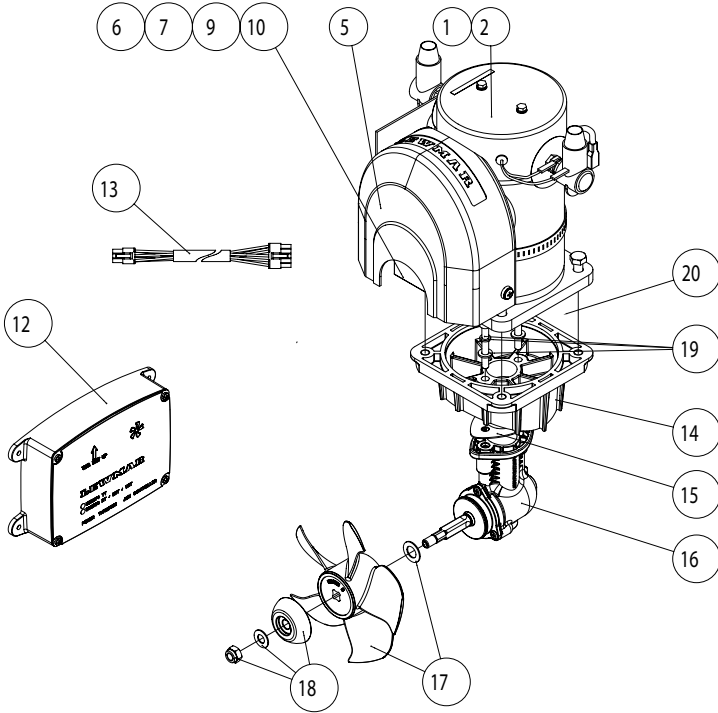

ITEM	PART NO	DESCRIPTION
1	581110	MOTOR ASSY 2.0KW 12v
2	581111	MOTOR ASSY 2.2KW 12v
3	581112	MOTOR ASSY 2.0KW 12v IP
4	581113	MOTOR ASSY 2.2KW 12v IP
5	553034	COVER, NON-IP
6	B12526	SOLENIOD 2.0
7	589857	SOLENIOD 2.0 LOOM, NON-IP
8	589856	SOLENIOD 2.0 LOOM, IP
9	B11126	SOLENIOD 2.2
10	589836	SOLENIOD 2.2 LOOM, NON-IP
11	589844	SOLENIOD 2.2 LOOM, IP
12	589274	GEN2 TT ICU
13	589806	2m TT MOTOR LOOM
14	551052	MOUNTING SADDLE
15	551035	TUNNEL GASKET
16	581005	HUB ASSY
17	589151	PROPELLER AND WASHER
18	589150	PROPELLER ANODE KIT
19	559152	INSTALLATION FIXING KIT
20	559018	DRIVE PIN

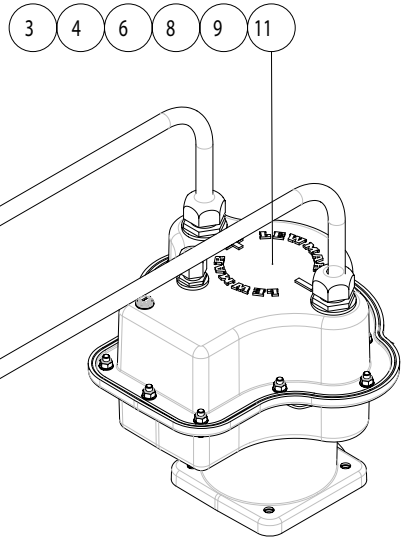

7.3 Model 185TT/H - 3.0 to 6.0kW - 12 G 24V

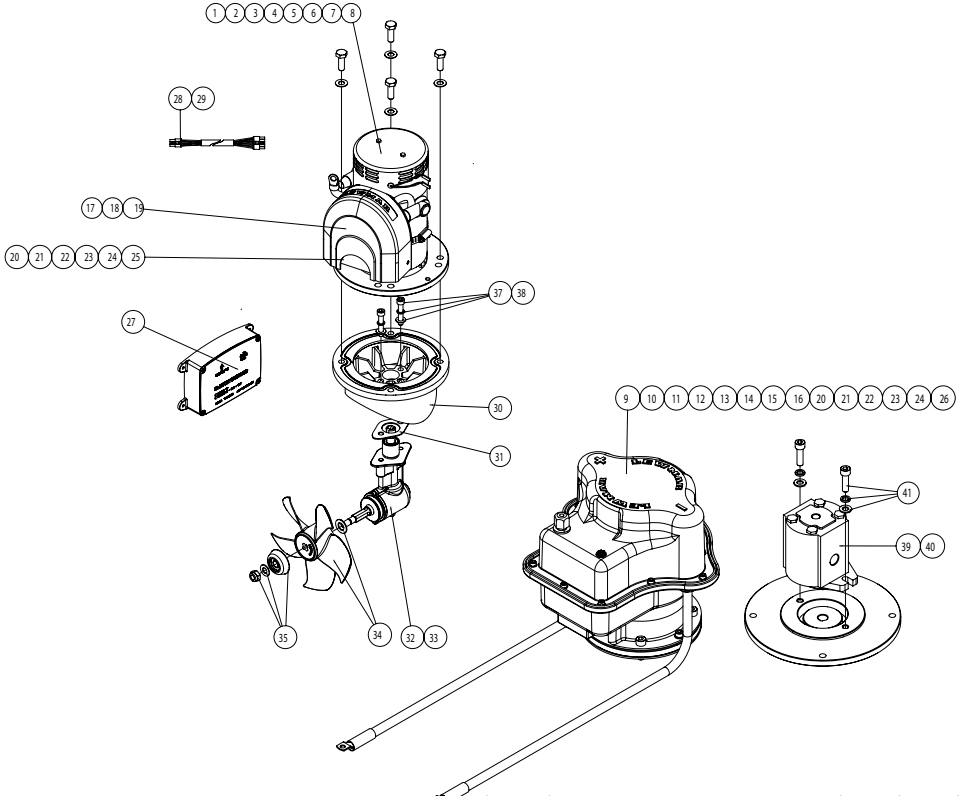

ITEM	PART NO	DESCRIPTION	KW	V
1	583082	185 3.0KW 12V MX	3.0	12
2	583083	185 3.0KW 24V MX	3.0	24
3	583084	185 4.0KW 12V MX	4.0	12
4	583085	185 4.0KW 24V MX	4.0	24
5	583086	185 5.0KW 12V MX	5.0	12
6	583087	185 5.0KW 24V MX	5.0	24
7	583088	185 6.0KW 12V MX	6.0	12
8	583089	185 6.0KW 24V MX	6.0	24
9	583090	185 3.0KW 12V MX IP	3.0	12
10	583091	185 3.0KW 24V MX IP	3.0	24
11	583092	185 4.0KW 12V MX IP	4.0	12
12	583093	185 4.0KW 24V MX IP	4.0	24
13	583094	185 5.0KW 12V MX IP	5.0	12
14	583095	185 5.0KW 24V MX IP	5.0	24
15	583096	185 6.0KW 12V MX IP	6.0	12
16	583097	185 6.0KW 24V MX IP	6.0	24
17	553034	COVER, NON-IP, 3.0	3.0	ALL
18	553036	COVER, NON-IP, 4.0/5.0	4/5.0	ALL
19	555034	COVER, NON-IP, 6.0	6.0	ALL
20	B11126	SOLENIOD 3.0 12V	3.0	12

ITEM	PART NO	DESCRIPTION	KW	V
21	B11127	SOLENIOD 3.0 24V	3.0	24
22	B11128	SOLENIOD 4/5/6.0 12V	4/5/6.0	12
23	B11129	SOLENIOD 4/5/6.0 24V	4/5/6.0	24
24	B11130	SOLENIOD 6.0 12V	6.0	12
25	589834	SOLENIOD LOOM		ALL
26	589844	SOLENIOD LOOM IP		ALL
27	589274	GEN2 TT ICU		ALL
28	589806	2m TT MOTOR LOOM		ALL
29	589858	2m TT HYD LOOM (HYDRAULIC ONLY)		ALL
30	553071	MOUNTING SADDLE		ALL
31	553035	TUNNEL GASKET		ALL
32	583001	HUB ASSY 3.0	3.0	ALL
33	583003	HUB ASSY 4/5/6	4/5/6.0	ALL
34	589351	PROPELLER & WASHER		ALL
35	589350	ANODE KIT		ALL
36	559017	DRIVE PIN		ALL
37	589352	INSTALLATION FIXING KIT	3.0	ALL
38	589355	INSTALLATION FIXING KIT	4/5/6.0	ALL
39	585040	HYD MOTOR 26 CC/REV		5.0CC REV
40	585041	HYD MOTOR 16.8 CC/REV		6.0CC REV
41	589352	INSTALLATION FIXING KIT		ALL

**7.4 Model 250TT/H - 8.0kW - 24V**

**7.5 Model 300TT/H - 10.8 to 15.0kW**

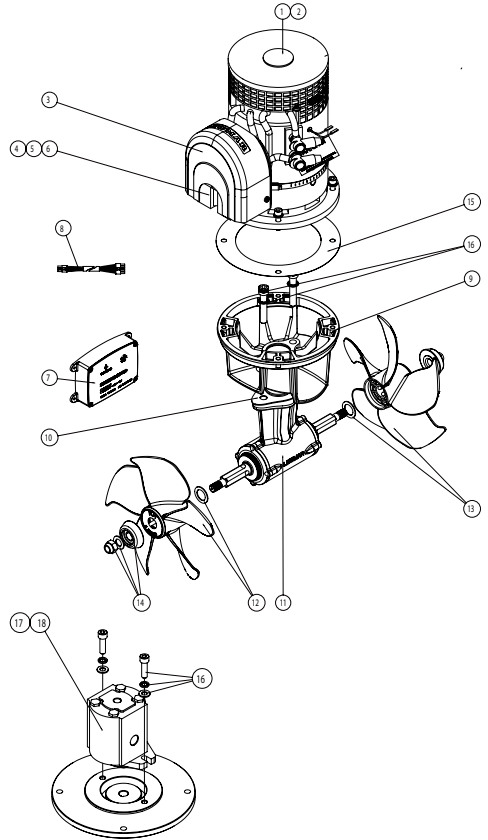
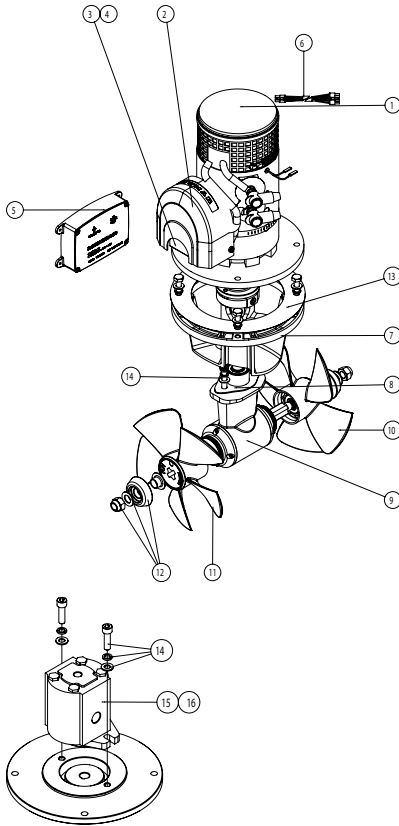

ITEM	PART NO	DESCRIPTION
1	585029	MOTOR ASSY 8.0KW 24v
2	553036	COVER, NON-IP
3	B11129	SOLENIOD 8.0
4	589834	SOLENIOD LOOM
5	589834	GEN2 TT ICU
6	589806	2m TT MOTOR LOOM
7	589858	2m TT HYD LOOM (HYDRAULIC ONLY)
8	555025	MOUNTING SADDLE
9	555035	TUNNEL GASKET
10	589557	HUB ASSY
11	589551	RIGHT HAND PROPELLER & WASHER
12	589552	LEFT HAND PROPELLER & WASHER
13	589150	ANODE KIT
14	555038	PLASTIC WASHER
15	559152	INSTALLATION FIXING KIT
16	585040	HYD MOTOR 26 CC/REV
17	585041	HYD MOTOR 16.8 CC/REV

ITEM	PART NO	DESCRIPTION
1	587032	MOTOR ASSY 10.8KW 24v
2	557030	MOTOR ASSY 15KW 48v
3	555034	COVER, NON-IP
4	B8429	SOLENIOD 10.8KW
5	B11762	SOLENIOD 15KW
6	589834	SOLENIOD LOOM
7	589274	GEN2 TT ICU
8	589806	2m TT MOTOR LOOM
9	589858	2m TT HYD LOOM (HYDRAULIC ONLY)
10	557025	MOUNTING SADDLE
11	557035	TUNNEL GASKET
12	559755	HUB ASSY
13	589750	RIGHT HAND PROPELLER & WASHER
14	589751	LEFT HAND PROPELLER & WASHER
15	589150	ANODE KIT
16	555038	PLASTIC WASHER
17	589752	INSTALLATION FIXING KIT
18	585040	HYD MOTOR 26 CC/REV
19	585041	HYD MOTOR 16.8 CC/REV

## 8- Accessories

ITEM	PART NO	DESCRIPTION
1	589222	Controller, Dual Pad
2	589223	Controller, Single Pad
3	589267	Controller, Dual Joystick
4	589268	Controller, Single Joystick
5	589845	Controller, Single, Hyd
6	589846	Controller, Dual, Hyd
7	589807	5m TT Motor Loom MX
8	589800	Gen2 Y Loom MX
	589801	Gen2 AUX 2m Loom MX
	589802	Gen2 AUX 7m Loom MX
9	589803	Gen2 AUX 10m Loom MX
	589804	Gen2 AUX 18m Loom MX
	589805	Gen2 AUX 22m Loom MX
10	589006	Fuse Holder
11	589010	T2 Fuse Holder
	589007	130 A ANL TYPE FUSE
	589008	250 A ANL TYPE FUSE
12	589009	325 A ANL TYPE FUSE
	589010	400 A ANL TYPE FUSE
	589011	500 A ANL TYPE FUSE
	589012	200 A ANL TYPE FUSE
	589064	MOTOR SUPPORT BRACKET 185 TT
13	589065	MOTOR SUPPORT BRACKET 300 TT
	589066	MOTOR SUPPORT BRACKET 250 TT
	589096	MOTOR SUPPORT BRACKET 140 TT
14	589810	Gen2 ABS 12v
	589830	Gen2 ABS 24v
15	589811	Gen2 PS 24v/12v
	589813	Gen2 PS 48v/24v

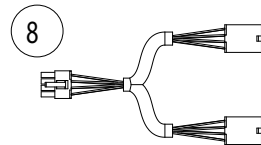
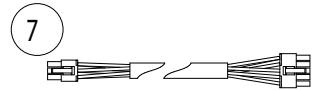
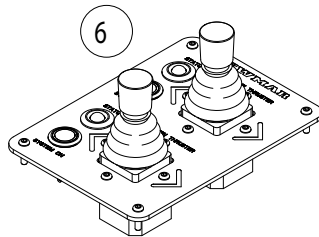
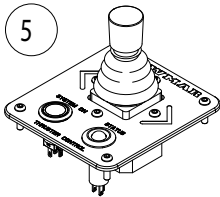
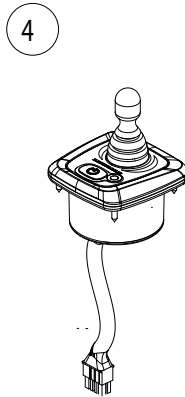
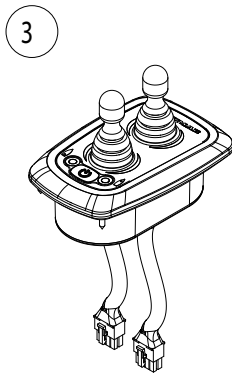
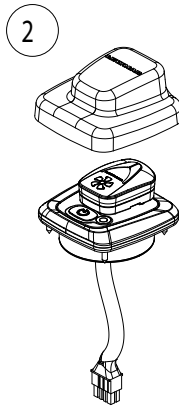
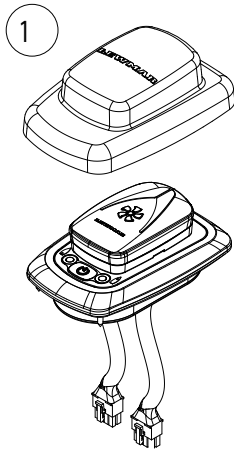

## 9- Dimensions

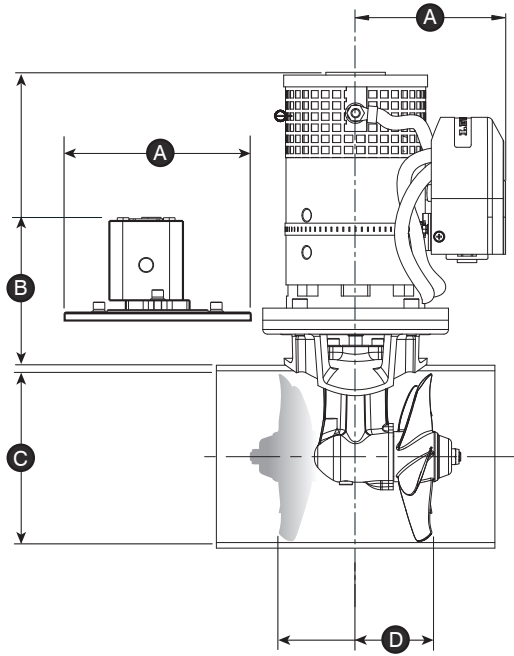

### 9.1 Electric

MODEL	VOLTAGE	POWER	A		B		C		D	
			mm	in	mm	in	mm	in	mm	in
110TT	12 V	1.5KW (2.0 hp)	123	4 5/8	261	10 1/4	110	4 1/3	67	2 5/8
140TT 2.2	12 V	2.2 kW (3.0 hp)	123	4 5/8	211	8 5/16	140	5 1/2	73	2 7/8
185TT 3.0	12 V	3.0 kW (4.0 hp)	130	5 1/8	271	10 21/32	185	7 9/32	85	3 11/32
185TT 3.0	24 V	3.0 kW (4.0 hp)	130	5 1/8	271	10 21/32	185	7 9/32	85	3 11/32
185TT 4.0	12 V	4.0 kW (5.4 hp)	148	5 13/16	294	11 9/16	185	7 9/32	85	3 11/32
185TT 4.0	24 V	4.0 kW (5.4 hp)	148	5 13/16	294	11 9/16	185	7 9/32	85	3 11/32
185TT 5.0	12 V	5.0 kW (6.7 hp)	162	6 3/8	316	12 7/16	185	7 9/32	85	3 11/32
185TT 5.0	24 V	5.0 kW (6.7 hp)	162	6 3/8	316	12 7/16	185	7 9/32	85	3 11/32
185TT 6.0	12 V	6.0 kW (8.0 hp)	173	6 13/16	316	12 7/16	185	7 9/32	85	3 11/32
185TT 6.0	24 V	6.0 kW (8.0 hp)	173	6 13/16	316	12 7/16	185	7 9/32	85	3 11/32
250TT 8.0	24 V	8.0 kW (10.8 hp)	165	6 1/2	405	15 15/16	250	9 27/32	238	9 3/8
250TT 9.6	48 V	9.6 kW (13.0 hp)	165	6 1/2	405	15 15/16	250	9 27/32	238	9 3/8
300TT 10.8	24 V	10.8 kW (14.5 hp)	203	8	450	17 23/32	300	11 13/16	320	12 19/32
300TT 15.0	48 V	15.0 kW (20 hp)	203	8	450	17 23/32	300	11 13/16	320	12 19/32

### 9.2 Hydraulic

MODEL	KW	HP	A		B		C		D	
			mm	in	mm	in	mm	in	mm	in
185TTH	7	10	200	7 7/8	202	7 15/16	185	7 9/32	83	3 9/32
250TTH	15	20	258	10 5/32	234	9 7/32	250	9 27/32	238	9 3/8
300TTH	22.5	30	258	10 5/32	256	10 1/16	300	11 13/16	320	12 19/32

10- Cutting template

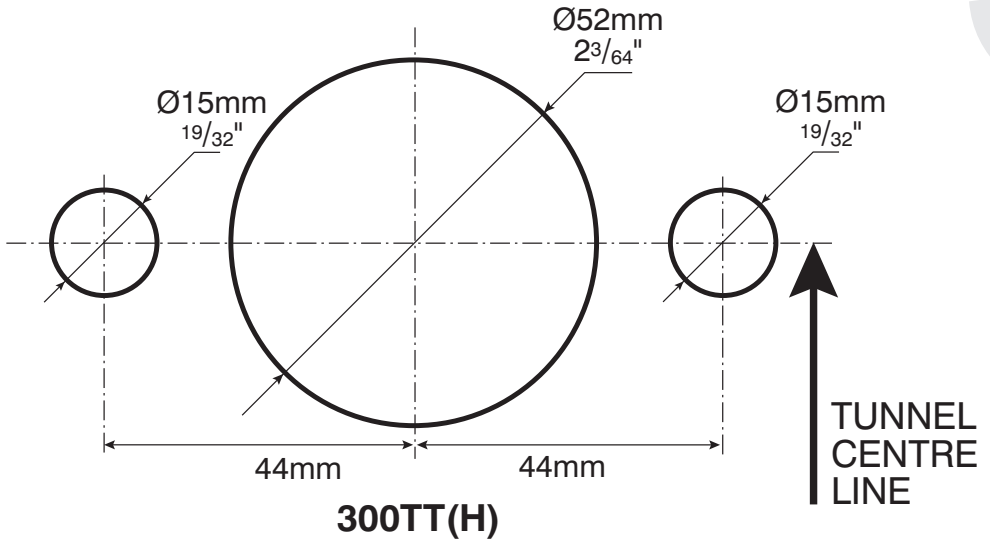
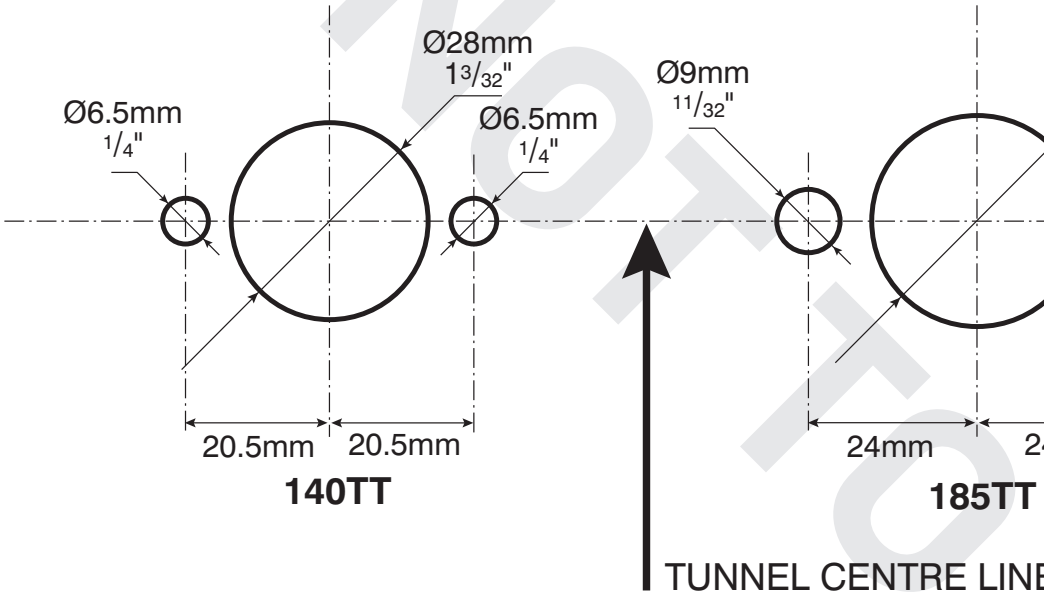



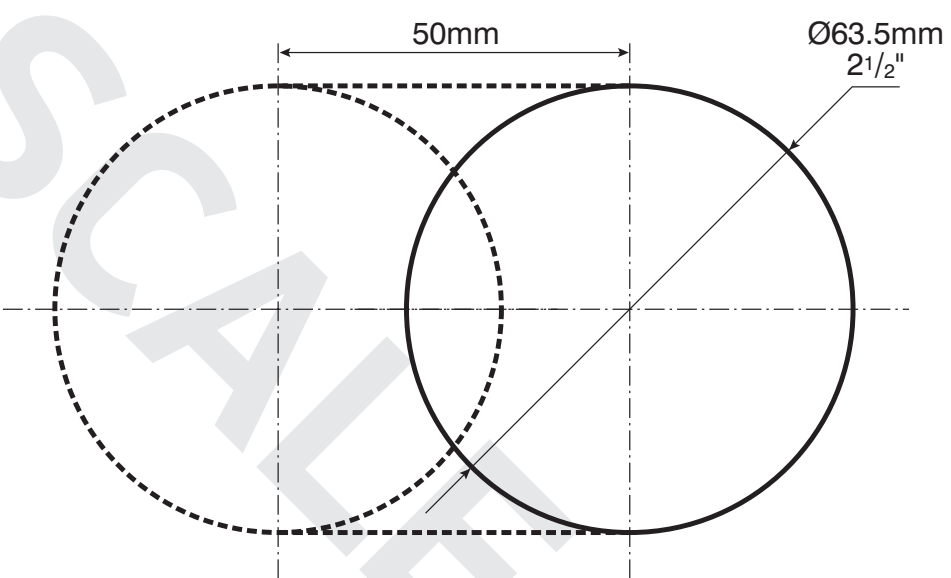
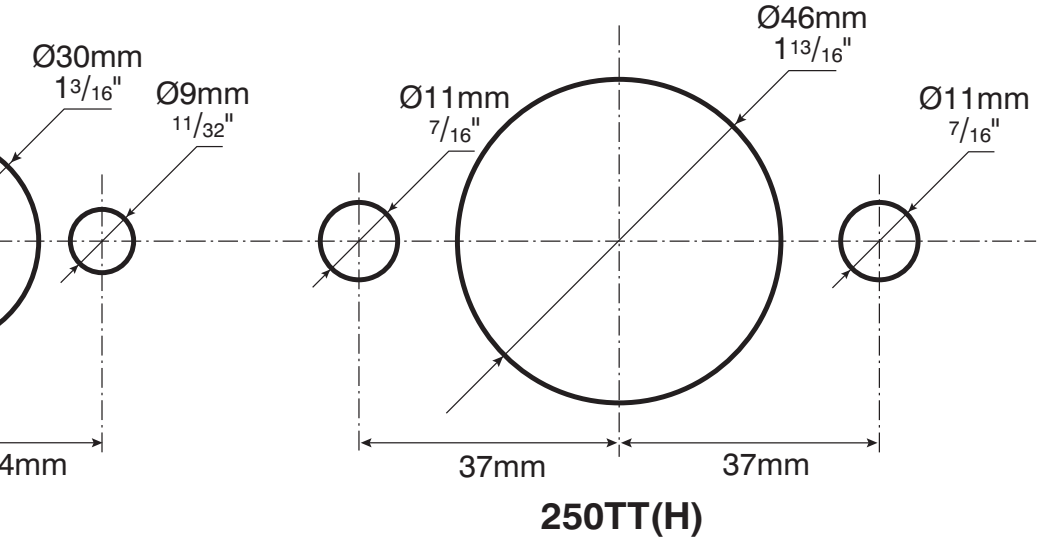

**SINGLE & DOUBLE  
CONTROL PANEL CUTOUT**

## 11- Fault finding

Thrust in wrong direction?	Change contactor wires on motor solenoid (See section 4.1).
Fuse keeps blowing?	<ul style="list-style-type: none"> <li>▶ Wrong fuse fitted - check rating and replace.</li> <li>▶ Propeller restricted or jammed causing excessive load on motor - check and clear. Check that propeller washer is fitted see Section 3.6.</li> </ul>
Control panel does not illuminate?	<p>Check</p> <ul style="list-style-type: none"> <li>▶ Power - Hold <math>\odot</math> for 1 second</li> <li>▶ Battery is connected.</li> <li>▶ Main switch ON, check fuse.</li> <li>▶ Control loom connections.</li> <li>▶ Long operation has tripped thermal switch. Wait 20 minutes for motor to cool and reset.</li> </ul> <p>⚠ DO NOT attempt to cool motor by any other means.</p>
Control panel illuminates but no thrust?	<ul style="list-style-type: none"> <li>▶ Are batteries charged?</li> <li>▶ Check main motor connections are tight.</li> </ul>
Poor thrust or thrust in one direction only?	<ul style="list-style-type: none"> <li>▶ Batteries not large enough or charged, cables not recommended size. Voltage at motor when running should be a minimum 10V for 12V and 21V for 24V units.</li> <li>▶ Blockage in tunnel/propeller jammed with debris, switch off main power, inspect and clear.</li> <li>▶ Propeller washers fitted wrong. See Section 3.6</li> <li>▶ Check motor brush springs are located properly, brushes should have good contact with the commutator.</li> </ul>
Motor turns but no drive? (140TT and 185TT only)	<p>⚠ DO NOT continue to run thruster.</p> <ul style="list-style-type: none"> <li>▶ Shear pin broken, remove 4 motor bolts, see Sec. 5.2, drive out old pin and replace with new pin.</li> <li>▶ Propeller blades broken. Replace with new.</li> </ul>
Thruster noisy and vibrating?	<ul style="list-style-type: none"> <li>▶ Check propeller is not touching the tunnel wall.</li> <li>▶ 140-185 models - Check hub height is correct, see section 3.4.</li> </ul>

## 12- Warranty

### Limited Warranty and Key Terms of Supply by Lewmar

Lewmar warrants that in normal private pleasure boat usage and with proper maintenance its products will conform with their specification for a period of three years from the date of purchase by the end user, subject to the conditions, limitations and exceptions listed below. Any product, which proves to be defective in normal usage during that three-year period, will be repaired or, at Lewmar's option, replaced by Lewmar.

#### A CONDITIONS AND LIMITATIONS

- i Lewmar's liability shall be limited to the repair or replacement of any parts of the product which are defective in materials or workmanship.
- ii Responsibility for the selection of products appropriate for the use intended by the Buyer shall rest solely with the Buyer and Lewmar accepts no responsibility for any such selection.
- iii Lewmar shall not be liable in any way for Product failure, or any resulting loss or damage that arises from:
  - a. use of a product in an application for which it was not designed or intended;
  - b. corrosion, ultra violet degradation or wear and tear;
  - c. a failure to service or maintain the product in accordance with Lewmar's recommendations;
  - d. faulty or deficient installation of the product (unless conducted by Lewmar);
  - e. any modification or alteration of the product;
  - f. conditions that exceed the product's performance specifications or safe working loads.
  - g. Abuse
- iv Product subject to a warranty claim must be returned to the Lewmar outlet that supplied the product for examination unless otherwise approved by Lewmar in writing.
- v This warranty does not cover any incidental costs incurred for the investigation, removal, carriage, transport or installation of product.
- vi Service by anyone other than authorized Lewmar representatives shall void this warranty unless it accords with Lewmar guidelines and standards of workmanship.
- vii Lewmar's products are intended for use only in the marine environment. Buyers intending to use them for any other purpose should seek independent professional advice as to their suitability. Lewmar accepts no liability arising from such other use.

#### B EXCEPTIONS

Cover under this Warranty is limited to a period of one year from the date of purchase by the end user in the case of any of the following products or parts of products:

- Electric motors and associated electrical equipment
- Electronic controls
- Hydraulic pumps, valves and actuators
- Hatch & Portlight weather seals
- Products used in "Grand Prix" racing applications
- Products used in commercial or charter applications
- Anchor rodes

#### C LIABILITY

- i Lewmar's liability under this warranty shall be to the

exclusion of all other warranties or liabilities (to the extent permitted by law). In particular (but without limitation):

- a. Lewmar shall not be liable for:
  - Any loss of anticipated turnover or profit or indirect, consequential or economic loss;
  - Damages, costs or expenses payable to any third party;
  - Any damage to yachts or equipment;
  - Death or personal injury (unless caused by Lewmar's negligence).

Some states and countries do not allow the exclusion or limitation of incidental or consequential damages, so the above limitation or exclusion may not apply to you

- b. Lewmar grants no other warranties regarding the fitness for purpose, use, nature or satisfactory quality of the products.

- ii Where applicable law does not permit a statutory or implied warranty to be excluded, then such warranty, if permitted by that state or country's law, shall be limited to a period of one year from the date of purchase by the end user. Some states and countries do not allow limitations on how long an implied warranty lasts, so this limitation may not apply to you.

#### D PROCEDURE

Notice of a claim for service under this warranty shall be made promptly and in writing by the end user to the Lewmar outlet that supplied the product or to Lewmar Limited at Southmoor Lane, Havant, Hampshire PO9 1JJ, England.

#### E SEVERANCE CLAUSE

If any clause of this warranty is held by any court or other competent authority to be invalid or unenforceable in whole or in part, the validity of the remaining clauses of this warranty and the remainder of the clause in question shall not be affected.

#### F OTHER RIGHTS

This warranty gives you specific legal rights, and you may also have other legal rights, which vary from state to state and country to country. In the case of European States a Consumer customer (as defined nationally) has legal rights under the applicable national law governing the sale of Consumer Goods; this Warranty does not affect those rights.

#### G LAW

This warranty shall be governed by and read in accordance with the laws of England or the state or country in which the first end user is domiciled at the time of purchase of the product.

#### H DISPUTES

Any dispute arising under this warranty may, at the option of the end-user, be referred to alternative dispute resolution under the rules of the British Marine Federation or to the Courts of the State whose law shall govern the warranty or to the Courts of England and Wales.

The British Marine Federation may be contacted at Marine House, Thorpe Lea Road, Egham, England, TW20 8BF

## **UK & International Distribution**

Lewmar  
Southmoor Lane  
Havant  
Hampshire  
PO9 1JJ  
England

**Tel:** +44 (0)23 9247 1841

**Fax:** +44 (0)23 9248 5720

**Email:** [info@lewmar.com](mailto:info@lewmar.com)

## **USA**

Lewmar  
351 New Whitfield Street  
Guilford, CT  
06437  
USA

**Tel:** +1 203 458 6200

**Fax:** +1 203 453 5669

**Email:** [info@lewmarusa.com](mailto:info@lewmarusa.com)

# **LEWMAR<sup>®</sup>**

**[www.lewmar.com](http://www.lewmar.com)**

Part No 559231 Iss.1