

Rule Shower Drain Box

NEW

800 & 1100 GPH - AUTOMATIC SHOWER & SINK DRAIN SUMP BOX



Our new shower drain box provides ultimate pumping performance, which helps keep your boat clear of nuisance water, building on the genuine Rule design.

Rigorous engineering and testing helped generate the new series of Rule automatic shower and sink drain systems. Our products are tested to the highest standard, providing better efficiency for the toughest applications.

The new Rule shower drain systems have been designed to meet the needs of installers and end users. As well as reliable, fully automatic operation, the new Rule shower box is simple to install, has a sealed clip-on lid to prevent unwanted water splash and is fully serviceable without the need for any tools.

Our new designs include:

- **Powerful 800 GPH or 1100 GPH pump** – High capacity pump to cope with incoming grey water
- **Sealed polycarbonate lid** – Tough impact resistant material with gasket to prevent water splash
- **Fast Fix System** – Lid, pump, filter and float switch can be removed and serviced without tools
- **Threaded Port Fittings** – Improves installation by offering several combinations of port fittings including 3/4" (19mm), 1" (25mm), 1-1/8" (29mm), straight and 90° elbow fittings
- **Simple Installation** – Easy access side rails plus additional rear bracket option
- **Back Flow Prevention** – Reduces the amount of water that can siphon back to shower box

The Rule brand builds on over 50 years of operational excellence and application expertise with a broad range of solutions for the marine industry.



ISO 8849 Marine (Electric bilge pumps)
ISO 8846 Marine (Ignition protection)

rule
a xylem brand

Rule...The world's most trusted pumps™

Rule Shower Drain System



| Nominal GPH/LPH | Model No. | Volts | Amps @ (V) | | Ports | Check Valve | Discharge Hose Dia. | UPC |
|-----------------|-----------|-------|------------|-------------|-------|-------------|---------------------|---------------|
| 800 (3028) | 98B | 12 DC | 2.9 (12V) | 3.5 (13.6V) | YES | YES | 3/4" (19mm) | 042237-106551 |
| 800 (3028) | 98B-24 | 24 DC | 1.5 (24V) | 1.8 (27.2V) | YES | YES | 3/4" (19mm) | 042237-106568 |
| 1100 (4164) | 99B | 12 DC | 3.7 (12V) | 4.5 (13.6V) | YES | YES | 1-1/8" (29mm) | 042237-106575 |
| 1100 (4164) | 99B-24 | 24 DC | 1.8 (24V) | 2.2 (27.2V) | YES | YES | 1-1/8" (29mm) | 042237-106582 |

Flow – GPH (LPH)

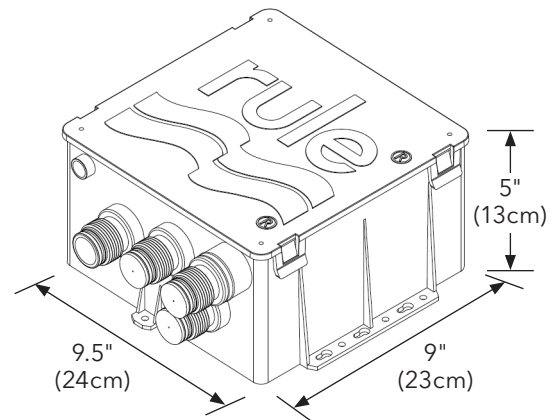
| GPH Series | @ 0ft 0m - 0kPa | @ 3.3ft 1m - 10kPa | @ 6.7ft 2m - 20kPa | Max. Head Height |
|------------|--------------------|-----------------------|-----------------------|------------------|
| 800 | 957 (3617) | 677 (2557) | 439 (1658) | 12' (3.7m) |
| 1100 | 1145 (4329) | 831 (3140) | 504 (1903) | 10' (3m) |

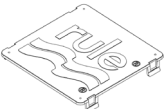

Replacement Parts

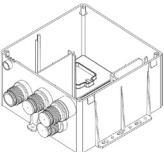
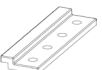
| | Description | Replacement Part No. |
|---|---------------------------------|----------------------|
| (a)  | Cover With Gasket (a) | 1242R |
| | Gasket Only (not shown) | 1243R |
| (b)  | Strainer (b) | 1244R |
| (c)  | Shower Drain Box Only (c) | 1245R |
| | Rear Mounting Bracket (d) | 1246R |
| | 800 GPH Replacement Pump - 12V | 20DA |
| | 800 GPH Replacement Pump - 24V | 20DA-24 |
| | 1100 GPH Replacement Pump - 12V | 27DA |
| | 1100 GPH Replacement Pump - 24V | 27DA-24 |
| (d)  | Float Switch | 35A or 37A |



Warranty: All products of the company are sold and all services of the company are offered subject to the company's warranty and terms and conditions of sale, copies of which will be furnished upon request. The information provided herein is for guidance only, it does not constitute a guarantee of the performance or specification of any individual product or component.

marine.xylem.com

USA
Xylem Inc.
100 Cummings Center
Suite 535N Beverly MA, 01915
Tel: (978) 281-0440
Fax: (978) 283-2619

UK
Xylem Inc.
Bingley Road, Hoddesdon
Hertfordshire EN11 0BU
Tel: +44 (0) 1992 450145
Fax: +44 (0) 1992 467132

GERMANY
Xylem Inc.
Oststrasse 28
22844 Norderstedt
Tel: +49-40-53 53 73-0
Fax: +49-40-53 53 73-11

PHILIPPINES
Xylem Inc.
12 Ring Road, LISP II
Brgy. Lamesa, Calamba City 4027
Tel: 63 (49) 5434341
Fax: 63 (49) 5456817

CHINA
Xylem Inc.
30/F Tower A, 100 Zunyi Road
Shanghai, China 200051
Tel: +86-21-2208-2888
Fax: +86-21-2208-2999

ITALY
Xylem Inc.
Via Tommaseo, 6 20059
Vimercate, Milano
Tel: +39 039 685 2323
Fax: +39 039 666 307